



AISBERG



MOZZARELLA

refrigerating cabinet

Mozzarella is a specialized refrigerated display for selling of brine Italian mozzarella cheese.

The idea of this display is an effective exposition and sale of Italian mozzarella cheese in compliance with the temperature and sanitary conditions necessary for its ripening and quality.



Mozzarella refers to pickled cheeses, which are prepared in their homeland in Italy for daily consumption in the freshest form. Therefore, **the shelf life and sale of mozzarella cheese is limited.**

The final cooking technology involves immersing the cheese in a cold brine. **The prerequisites for preserving the taste of mozzarella are the temperature not higher than +7°C and full immersion in the brine,** otherwise the cheese dries up and deteriorates.

Refrigerated display Mozzarella is equipped with a sealed stainless steel container for the sale of cheese in cold brine.

The level of the exposition surface made of food grade plastic is regulated depending on the amount of the offered product and is sufficient for its complete immersion in the brine.

The display container is segmented into three equal parts with stainless steel dividers for selling of mozzarella of various sizes and shapes.



All parts of display, which can come into contact with salty environment, are made of stainless steel of the appropriate grade, which can withstand the aggressive effects of salt. For the same reason, the manufacturer does not recommend painting or finishing the display with decorative materials.

The cabinet is equipped with an autonomous cooling system. It is connected to the sewage system for draining the used brine and for simple sanitization.

Temperature range: +2/+6 °C



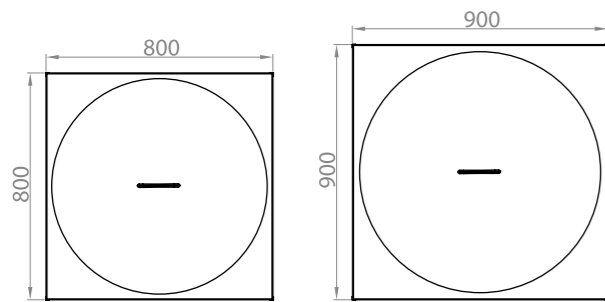

The rectangular shape of the Mozzarella cabinet allows easy integration into the line of traditional refrigerated counters for the sale of gastronomy.

Standard options:

- autonomous cooling and temperature control system,
- drainage system,
- stainless steel cover.

Additional option:

- transparent acrylic cover.



Model	Overall dimensions, mm	Temperature, °C	Max volume of refrigerated exposition tank, l	Max useful volume of the refrigerated exposition tank, l	Voltage, V	Cooling capacity, kW	Power consumption, kW
Mozzarella - 800	800*800*H900	+2/+6	76	50	220	0,7	0,4
Mozzarella - 900	900*900*H900		100	60		0,75	0,46

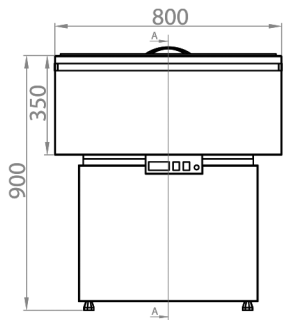

MOZZARELLA-800

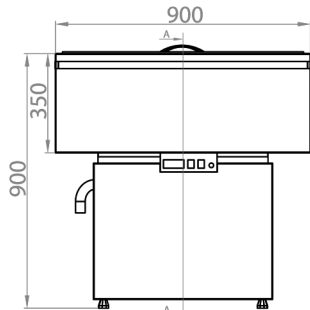
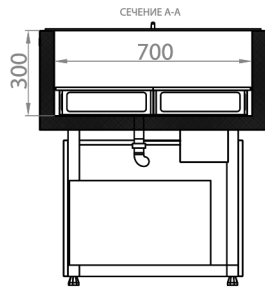

MOZZARELLA-900

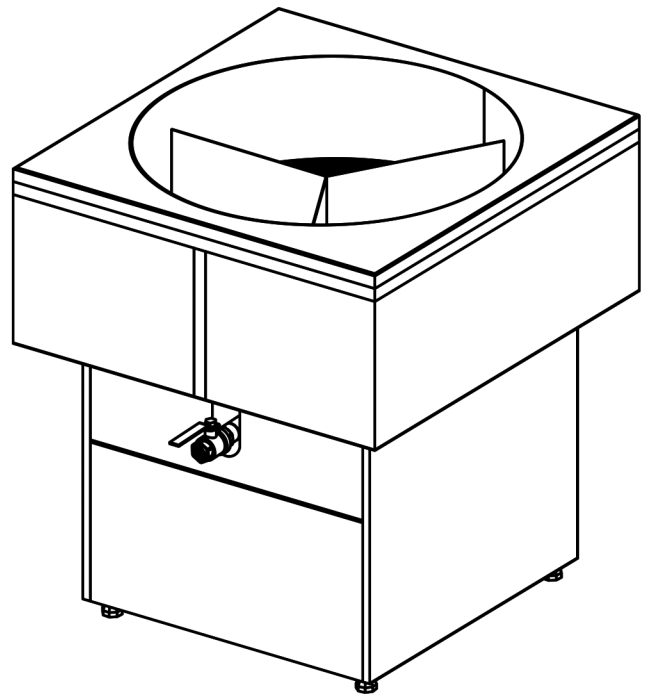
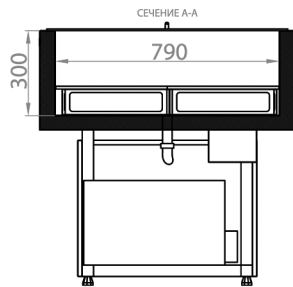

*EFFECTIVE
TRADE
TECHNOLOGIES*

Aisberg Ltd

3, Ovidiopolska doroga
Odesa, 65036, Ukraine
Ph./fax: +38 (0482) 32-35-27, -28, -29

aisberg@aisberg.od.ua
www.aisberg.com

Aisberg Europe

Bucharest, Romania
Mob: +40 (729) 00-44-43
Mob: +38 (050) 506-03-51

aisberg.europe@aisberg.od.ua
www.aisberg.com

Aisberg delivers displays anywhere in the world through a chain of professional distribution companies that provide logistics, installation and service services. Contact our regional managers:

export.mail@aisberg.od.ua
(export orders)

sasha@aisberg.od.ua
(for orders from Ukraine and CIS countries)

kd@aisberg.od.ua
(for orders from Ukraine and CIS countries)

fatinar@aisberg.od.ua
(for orders from Armenia, Azerbaijan, Georgia)

